

MODEL BKE

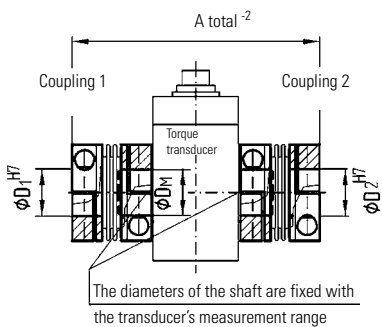
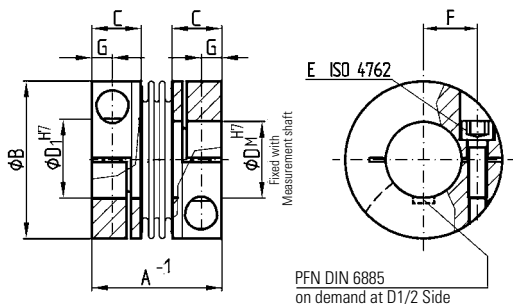

Properties:

- compact design
- easy to mount
- suited for space restricted installations
- low moment of inertia
- economically priced

Material:

Bellows are made of highly flexible high-grade stainless steel, hubs see table

Design:

With a single radial clamping screw per hub ISO 4762

Self opening clamp system optional:
Loosening the clamp screw will force the clamp into open position

Temperature range:

-30 to +100° C

Backlash:

Absolutely backlash-free due to frictional clamped connection

Service life:

These couplings have an infinite life and are maintenance-free if technical limits are not exceeded

Tolerance:

On the hub / shaft connection 0,01 to 0,05 mm

Non-standard:

Custom designs with varied tolerances, keyways, Non-standard material and bellows are available upon request

Model BKE	Series			
		20	200	1000
Rated torque (Nm)	T_{KN}	20	200	1000
Overall length (mm)	A^{-1}	40	59	89
Overall length for installation (mm)	A_{total}^{-2}	130	172	246
Outer diameter (mm)	B	49	66	110
Passungslänge (mm)	C	16,5	23	34
Inner diameter possible from \emptyset to \emptyset H7 (mm)	$D_{1/2}$	15-28	24-35	40-60
Inner diameter for meas. shaft \emptyset H7 (mm)	D_M	15	24	40
Screws ISO 4762		M5	M8	M12
Tightening torque of the fastening screw (Nm)	E	8	40	130
Distance between centers (mm)	F	17	23	39
Distance (mm)	G	6	9,5	13
Mass moment of inertia (10^{-3} kgm ²)	J_{total}	0,05	0,18	7,2
Hub material		AL	AL	Stahl
Approx. weight (kg)		0,13	0,4	3,5
Torsional stiffness (10^3 Nm/rad)	C_T	41,9	138	1210
Axial total (mm)		1	1,5	2
Lateral total (mm)	max. Values	0,15	0,15	0,15
Angular total (°)		1	1	1
Axiale spring stiffness (N/mm)	C_a	55,8	153	148
Laterale spring stiffness (N/mm)	C_r	3.710	11.000	9.010
Max. speed (1/min)	n	22.000	16.000	9.000

Ordering example

