

MCRT[®] 59000V NON-CONTACT DC OPERATED TORQUEMETERS HAVE INDUSTRIES HIGHEST SAFETY MARGINS

For 4X and 2X overload versions of the MCRT[®] 59000V see Bulletins 7400 and 7401. Similar units are also available with mV/V and 4-20 mA outputs.

For Use When The Peak To Average Torque Ratio Is High

- ✓ Starting, Stopping And Reversing Inertia Loads
- ✓ On Diesel And Single Cylinder Engine/Compressor Drives
- ✓ When Shaft Torsionals Are Present
- ✓ Or To Reduce Risks When Peak Torques Are Unknown

Outstanding Features

- ✓ 10X Intrinsic Overload Capacity — No Mechanical Stops
- ✓ 0.1% Accuracy NIST Traceable*, And Remote Calibration
*Calibration performed in our accredited metrology laboratory (NVLAP Lab Code 200487-0). For details see www.himmelstein.com or accreditation link at www.nist.gov.
- ✓ Highest Torsional Stiffness Shaft End and Flange End Units
- ✓ Hardened To EMI From IGBT-based Adjustable Speed Drives

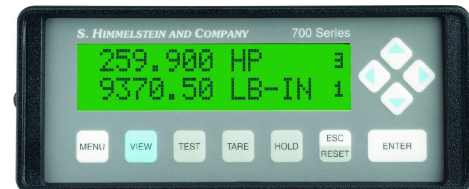
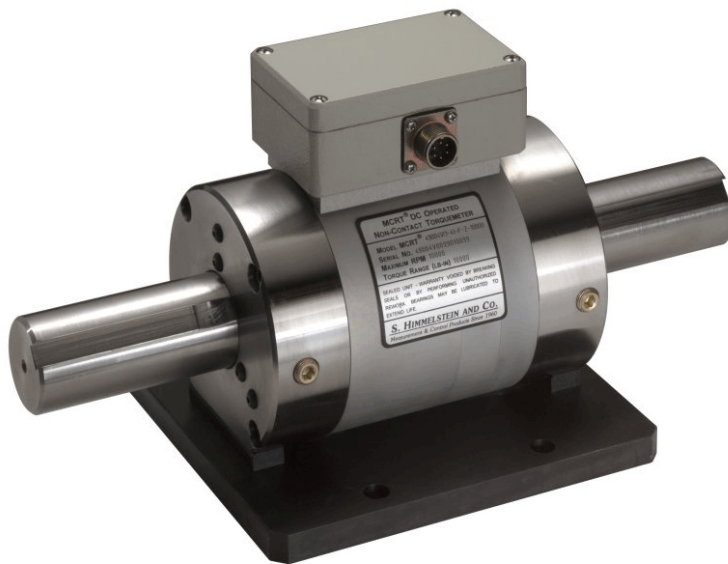

To excite and display Torque only, use a Model 703. To excite and display Torque, Speed and HP, use a Model 723. See Bulletins 374 & 372.



Measurement Ranges: 40 to 735,000 lbf-in (4.52 to 83,000 N-m)

5 Volt Output Interfaces PC and PLC Controllers and Data Acquisition Systems

S. HIMMELSTEIN AND COMPANY

Designing and Making the World's Best Torque Instruments Since 1960

Features

- 10X Intrinsic Overload Capacity Without Stops — Provides Industries Highest Safety Margins
- Hardened To EMI From Adjustable Speed Drives
- Dual ± 5 Volt Outputs — dc to 1 Hz & 500 Hz
- High Accuracy With Infinite Fatigue Life
- Highest Torsional Stiffness Shaft & Flange Units
- Static and Dynamic Response
- Bi-directional + Stall (Zero Speed) Operation
- NIST Traceable Remote Calibration
- Single DC Supply, Reverse Polarity Protected
- Immune to Vibration, Lubricants and Machinery Magnetic Fields
- One Piece, Alloy Steel Shaft
- Splashproof, Corrosion Resistant Construction
- Transformer Coupled Strain Gage Sensing
- Calibration & Balance Free of Cable Effects
- No Slip Rings, Brushes, LVDT's, Optical Paths, Ferrites, or Radio Transmitters
- Provides Direct Interface To PC and PLC Controllers and Data Acquisition Systems

Applications

- Electric, Air and Hydraulic Motors
- Gasoline, Diesel and Turbine Engines
- Pumps, Fans, Blowers, Compressors
- Gear, Belt, and Fluid Transmissions
- Chassis and Engine Dynamometers
- Machine Tools, Vehicle and Marine Drives
- Mixers, Extruders, Fluid Viscosity
- Clarifier Drives, Emulsifiers, Reactors
- Crushers, Pelletizers, Conveyers
- Rolling and Grain Mills, Grinders
- Winders, Paper Machines, Drill Rigs
- Or Virtually any Rotating Machinery

Benefits

The MCRT[®] 59000V series was developed to *safely measure average torque in the presence of high transient peaks*. In that situation, a conventional torque-meter must be oversized to avoid damage — a process which greatly reduces accuracy.

Conditions that can create high peak to average ratios include starting, stopping or reversing inertia loads, torsional oscillations, and diesel and single cylinder engine/compressor drives. If peak torques are unknown, using an MCRT[®] 59000V reduces the risk of damage from unexpected or accidental torque spikes.

Overload capacity is 10 times; achieved without mechanical overload stops which are ineffective under dynamic conditions. Because of their high intrinsic overload capacity and because they have higher torsional stiffness than other similar models, MCRT[®] 59000V's are *ideal for dynamic measurements*. They accurately measure low running torque without damage from starting torques, torsionals or transient spikes.

MCRT[®] sensors are world renowned for their tolerance of machinery fields and electrical noise. MCRT[®] 59000V's incorporate new advances that provide even *greater noise immunity* — they are hardened to the intense electromagnetic interference (EMI) often generated by modern, IGBT-based adjustable speed drives/controls.

Torquemeter Description

These devices use proprietary Himmelstein technology, field-proven since 1963 and newly refined to achieve MCRT[®] 59000V performance. A temperature compensated, strain gaged stainless shaft measures torque and cancels bending and thrust loads. *Rotary transformers* connect the gages to stationary circuitry without mechanical contact. Transformers don't generate noise or wear. Immune to noise, dirt and lubricants, Himmelsteins' *robust, non-ferrite design* protects against shock and vibration and has long, maintenance-free life. MCRT[®] 59000V sensors are suitable for diesel service and other hostile environments.

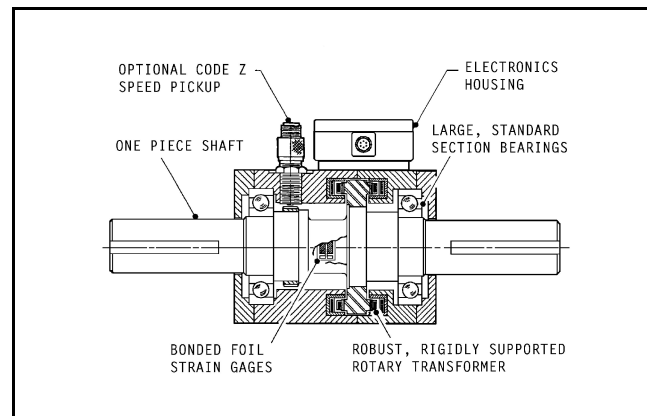

DC Operated Torquemeter Construction

RFI shielded circuitry, improved EMI tolerance, and the 5 volt output with low source impedance provide high noise immunity. Simple cabling yields *calibration and balance truly free of cable effects*. There are no slip rings, brushes, radio transmitters or other limited-life, noise-generating elements.

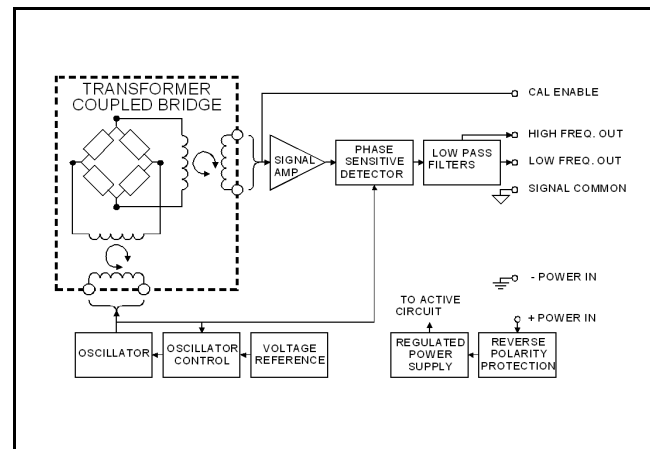

Simplified Block Diagram

Standard Ratings, Shaft End Models

MCRT® MODEL	TORQUE RANGE		TORQUE OVERLOAD		SPEED RATING	SHAFT STIFFNESS*	ROTATING INERTIA	MAX WT.
	[lbf-in]	[N-m]	[lbf-in]	[N-m]	[rpm]	[lbf-in/rad]	[ozf-in sec ²]	[lbs]
59001V(4-1)	40	4.52	400	45.2	0 to ±15,000	21,400	0.035	11
59002V(1-2)	100	11.3	1,000	113	0 to ±15,000	50,200	0.035	12
59002V(2-2)	200	22.6	2,000	226	0 to ±15,000	56,000	0.035	12
59003V(4-2)	400	45.2	4,000	452	0 to ±10,000	214,000	0.11	23
59004V(1-3)	1,000	113	10,000	1,130	0 to ±10,000	580,000	0.16	26
59004V(2-3)	2,000	226	20,000	2,260	0 to ±10,000	593,000	0.16	26
59006V(4-3)	4,000	452	40,000	4,520	0 to ±8,000	1,800,000	2.3	105
59006V(8-3)	8,000	904	80,000	9,040	0 to ±8,000	2,700,000	2.4	105
59007V(2-4)	20,000	2,260	200,000	22,260	0 to ±6,000	7,100,000	3.0	115
59008V(4-4)	40,000	4,520	400,000	45,200	0 to ±3,600	29,000,000	11.0	150
59008V(75-3)	75,000	8,470	750,000	84,700	0 to ±3,600	36,000,000	11.7	150
59009V(15-4)	150,000	16,900	1,500,000	169,000	0 to ±1,800	115,000,000	205	775
59009V(2-5)	200,000	22,600	2,000,000	226,000	0 to ±1,800	125,000,000	207	780
59009V(3-5)	300,000	33,900	3,000,000	339,000	0 to ±1,800	136,000,000	212	590
59009V(4-5)	400,000	45,200	4,000,000	452,000	0 to ±1,800	142,000,000	218	800
59010V(5-5)	500,000	56,500	5,000,000	565,000	0 to ±1,200	216,000,000	556	1,445
59010V(6-5)	600,000	67,800	6,000,000	678,000	0 to ±1,200	221,000,000	567	1,455
59010V(7-5)	700,000	79,100	7,000,000	791,000	0 to ±1,200	224,000,000	574	1,465
59010V(735-3)	735,000	83,000	7,350,000	830,000	0 to ±1,200	227,000,000	582	1,475

* Stiffness is conservatively rated and includes both the torsion section and shaft-ends.

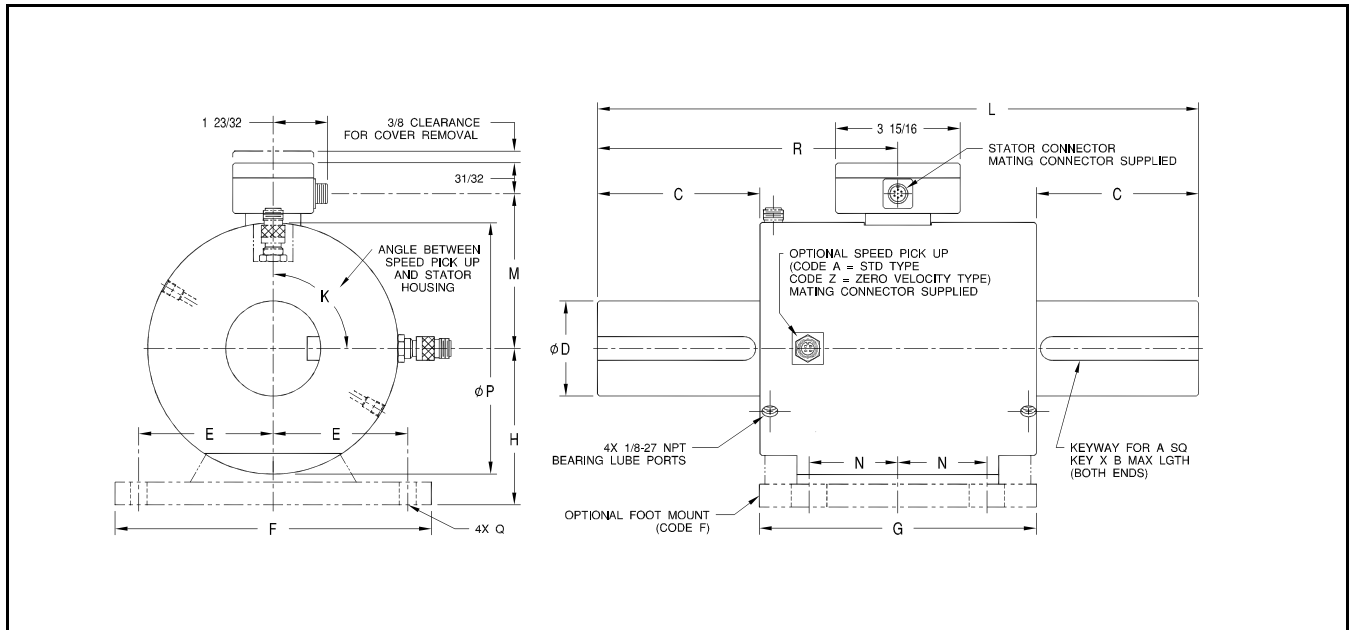

MCRT® MODEL	DIMENSIONS [inches]														
	A	B	C	D1	E	F	G	H	L	M	N	P	K	Q	R
59001V	0.187	1.125	1.50	0.625	2.25	5.50	5.50	2.250	8.50	2 9/16	1 ½	3 15/32	90°	0.406D	4 1/4
59002V	0.187	1.625	2.00	0.750	2.25	5.50	5.50	2.250	9.50	2 9/16	1 ½	3 15/32	90°	0.406D	4 3/4
59003V	0.250	1.750	2.00	1.000	2.625	6.25	7.00	2.500	10.00	2 31/32	1 ½	4 7/32	90°	0.406D	5
59004V	0.375	2.750	3.38	1.500	2.625	6.25	7.00	2.500	12.75	2 31/32	1 ½	4 7/32	90°	0.406D	6 3/8
59006V	0.625	3.500	4.13	2.500	4.25	10.00	8.75	5.000	17.00	4 7/8	2 13/16	7 15/16	0°	Note 2	9 ½
59007V	0.750	4.500	5.13	3.000	4.25	10.00	8.75	5.000	19.00	4 7/8	2 13/16	7 15/16	0°	Note 2	9 ½
59008V	1.000	6.500	7.56	4.500	4.25	10.00	7.75	5.000	23.00	5 1/8	2 13/16	8 ½	0°	Note 2	12 27/32
59009V	Note 3	8.000	9.00	7.750	7.00	15.50	18.00	8.000	36.00	7 7/8	7 7/8	13 7/8	0°	Note 2	18
59010V	Note 4	12	13.50	9.375	8.50	18.50	20.00	9.750	47.00	9 ½	8 7/8	17	0°	Note 2	23 ½

1. Tolerance on D diameter is +0.0000/-0.0005 for diameters < 2.5" and +0.000/-0.001 for diameters > 2.5". 2. Slotted 0.531 wide by 1-1/8 long.
3. Dual rectangular keyways at each end are 2" wide by 1.50" high. 4. Dual rectangular keyways at each end are 2.50" wide by 1.75" high.

Standard Ratings, Compact Flanged Models

MCRT [®] MODEL	TORQUE RANGE		TORQUE OVERLOAD		SPEED RATING	SHAFT STIFFNESS ^g	ROTATING INERTIA	MAX WT.
	[lbf-in]	[N-m]	[lbf-in]	[N-m]	[rpm]	[lbf-in/rad]	[ozf-in sec ²]	[lbs]
59060V(2-2)	200	22.6	2,000	226	0 to ±8,000	602,000	0.6	12½
59060V(4-2)	400	45.2	4,000	452	0 to ±8,000	1,375,000	0.6	12½
59060V(8-2)	800	90.4	8,000	904	0 to ±8,000	2,640,000	0.6	12½
59061V(2-3)	2,000	226	20,000	2,260	0 to ±8,000	2,930,000	0.9	15½
59061V(36-2)	3,600	407	36,000	4,070	0 to ±8,000	3,530,000	0.9	15½
59070V(48-2)	4,800	542	48,000	5,420	0 to ±5,500	6,800,000	8.24	50
59070V(96-2)	9,600	1,080	96,000	10,800	0 to ±5,500	12,200,000	8.27	50
59070V(192-2)	19,200	2,170	192,000	21,700	0 to ±5,500	17,900,000	8.33	52
59080V(4-4)	40,000	4,520	400,000	45,200	0 to ±3,600	39,200,000	54.5	150
59080V(75-3)	75,000	8,470	750,000	84,700	0 to ±3,600	53,100,000	54.9	155
59090V(15-4)	150,000	16,900	1,500,000	169,000	0 to ±1,800	137,000,000	480	974
59090V(3-5)	300,000	33,900	3,000,000	339,000	0 to ±1,800	164,000,000	487	989
59090V(4-5)	400,000	45,200	4,000,000	452,000	0 to ±1,800	177,000,000	493	998
59091V(6-5)	600,000	67,800	6,000,000	678,000	0 to ±1,200	282,000,000	1,838	1,502
59091V(735-3)	735,000	83,000	7,350,000	830,000	0 to ±1,200	292,000,000	1,852	1,516

^gStiffness is conservatively rated from flange face-to-face.

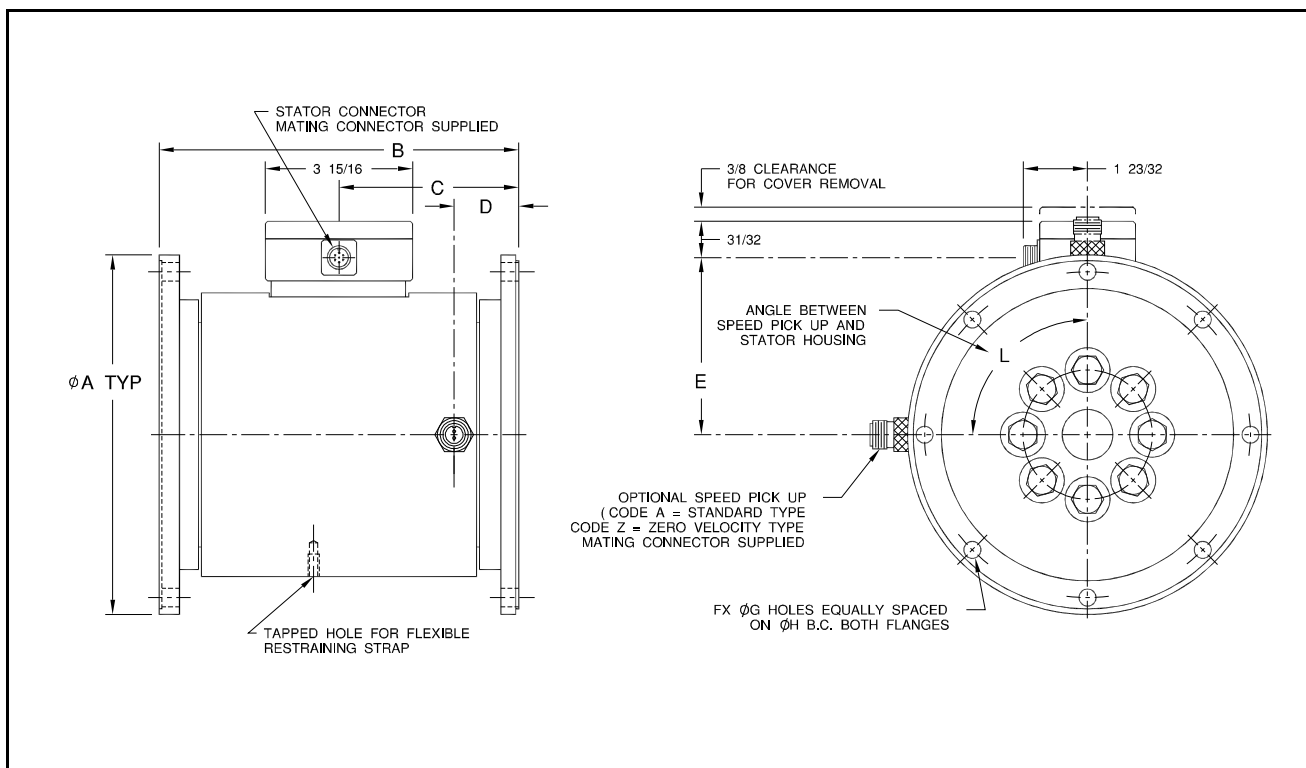

MCRT [®] MODEL	DIMENSIONS [inches]								
	A	B	C	D	E	F	G	H	L
59060V	4.250 ±0.001 (Flange faces are pilotless)	5 3/16	2 19/32	1 3/32	2 27/32	8	3/8-24UNF-2B	3.625	90°
59061V	4.250 ±0.001 (Flange faces are pilotless)	5 15/16	2 31/32	1 15/32	2 27/32	8	3/8-24UNF-2B	3.625	90°
59070V	8 (Flange faces have male and female pilots ^g)	8	4 1/32	1 7/16	4 1/16	8	0.377 +0.002/-0.000	7.250	0°
59080V	12 (Flange faces have female pilots ^g)	15 1/4	8 13/16	5 5/8	5 5/32	16	0.630 +0.002/-0.000	10.375	0°
59090V	23 (Flange faces have female pilots ^g)	31	15 ½	7 1/8	7 7/8	32	0.755 +0.002/-0.000	20.625	0°
59091V	30 (Flange faces have female pilots ^g)	37	18 ½	9 1/8	9 ½	32	1.005 +0.002/-0.000	27	0°

^gContact the factory for a print of flange details.

Shaft End and Flanged Models

Shaft end torque meters are the choice for most applications. They cost less than flanged models and, they can either be floated or foot mounted. Flanged torque meters are much shorter than the shaft end types. Therefore, flanged models are often used when axial space is insufficient to accommodate a longer shaft end model or, when the highest shaft stiffness is needed.

Flanged models handle large* axial or thrust loads *without special mounting considerations or hardware*. As a result, they are frequently used in marine or vehicular drives, to support the weight and thrust of a mixers' impeller, and in other similar circumstances. A *flanged torque meter must be installed as a floating shaft*.

* generally a thrust in pounds equal to the torque meters' full scale rating in pound-inches.

General Specifications

Non-linearity (end point method, % of F.S.):	≤ ± 0.07
Hysteresis (% of F.S.):	≤ ± 0.07
Non-repeatability (% of F.S.):	≤ ± 0.03
Combined Error (guaranteed combined non-linearity, hysteresis and non-repeatability, % of F.S.):	≤ ± 0.10
Rotational Effect on Zero (% of F.S.):	≤ ± 0.05
Remote¹ Calibration Error (% of F.S. @ 75 deg. F., traceable to NIST):	≤ ± 0.04
Temperature Effects:		
Zero (% of F.S./deg. F.):	≤ ± 0.0025
Span (% of Rdg./deg. F.):	≤ ± 0.0025
Compensated Range:	+ 75 to + 175 deg. F.
Minimum Usable Range:	-25 to + 185 deg. F.
Storage Range:	-65 to + 225 deg. F.
Outputs: Fully bi-directional, dual outputs with common characteristics, as follows		
Clockwise (CW) Torque ² :	Standard: +5 Volts ³ ; Option L: +10 Volts ³
Counterclockwise (CCW) Torque ² :	Standard: -5 Volts ³ ; Option L: -10 Volts ³
Minimum Resistive Load:	10 kΩ
Maximum Capacitive Load:	0.05 uF
Source Impedance:	< 1Ω
Overrange³ (% of F.S.):	± 33
Zero Control Range:	± 5% of F.S., nominal
Span Control Range:	± 5% of F.S., nominal
Supply Voltage⁵:	Standard: 10.5 to 24 Volts dc; Option L: 18 to 24 Volts dc
Supply Current⁵:	85 mA, nominal
Power Supply Effect:	< 0.01 % of F.S./volt
Measurement Bandwidth⁴:	High Frequency Output [Ⓢ] Standard: dc to 500 Hz Option K: dc to 1,100 Hz and, Low Frequency Output [Ⓢ] dc to 1 Hz; both outputs are present simultaneously.
Output Noise (rms, % of F.S.):	0.10 @ 500 Hz. output, 0.02 @ 1 Hz. output.

Notes

1. Calibration enabled by shorting CAL terminal to COMMON.
2. CW torque causes the torque meter shaft to turn CW when viewed from its driven end. CCW torque causes the opposite rotation.
3. Electrical outputs remain *linear* to the *overrange* level. A torque meter will not *yield* below its *rated overload torque*. *The region between 5X rated and overload torques should be reserved for unexpected loads*.
4. Bandwidth upper limit is determined by integral Bessel response filter. The torque meters' torsional resonant frequency is independent of the amplifier bandwidth; see Technical Memo Number 8150.
5. Fused and reverse polarity protected.
6. "F.S." denotes "Range Full Scale". "Rdg." denotes "Reading".
7. "deg. F." denotes "degree Fahrenheit".
8. Speed ratings are for continuous, bi-directional operation.
9. These torque meters will operate in a condensing atmosphere, and if wetted with non-corrosive fluids and mud. When operated continuously, clean regularly or cover to deflect contaminants. They are not submersible.
10. Specifications are subject to change without notice.

Installation

When it is installed between a driver and its' load, a torquemeter measures shaft torque. A shaft end torquemeter may be floated or, foot mounted as shown in the upper sketch. Both shaft end and flanged end types may be operated as floating shafts; see the lower illustration. A floating torquemeter handles the greatest axial loads, a foot mounted torquemeter operates at the highest speeds.

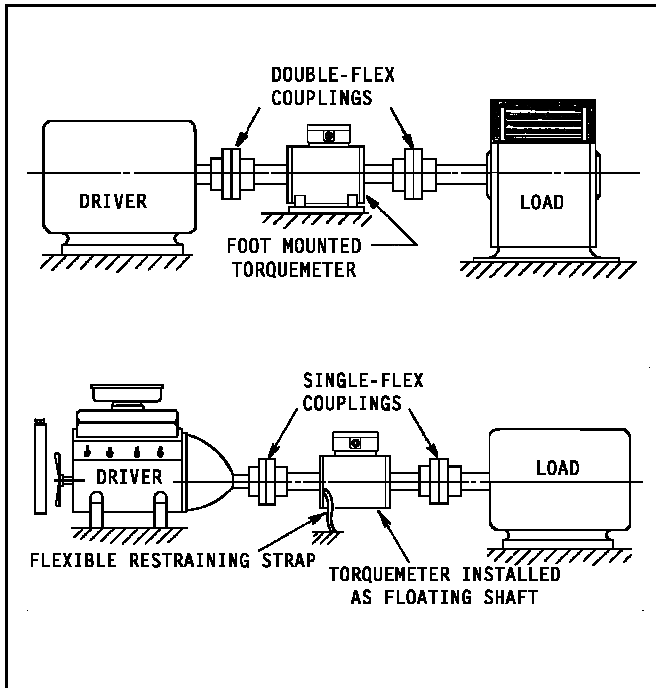

Connect an excitation voltage between 10.5 and 24 volts dc as shown. Both high (dc to 500 Hz.) and low frequency (dc to 1 Hz.) outputs are simultaneously available. The 1 Hz. output is used to eliminate vibratory signals; the other is used with fast controllers and/or for wideband data acquisition. The remotely operable calibration is enabled by shorting the CAL pin to COMMON. This NIST traceable, remotely operated, calibration verifies torquemeter operation and simplifies scaling of the customers' recording/control system.

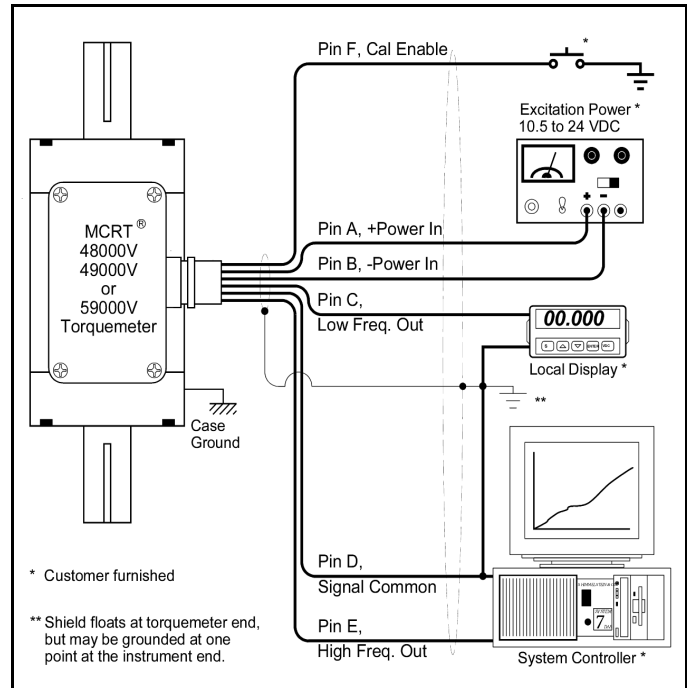

Available Options: Available options are listed. Consult the factory should you have special requirements.

Configuration - Code N if Standard, Code S if Special

This code identifies the torquemeter as being a standard configuration or flags the presence of a special modification(s).

Foot Mount - Code F, or N if None

Foot mounts provide a rigid stator mounting. They are only available on shaft end torquemeters. Refer to outline drawing for dimensions.

Code L - ± 10 Volt Output, N if ± 5 Volts

Add Suffix L for optional 10V outputs; requires 18V minimum power.

Order Number: MCRT[®] 59061V (2-3) - N - N - Z - L - K

Model No. and Range

Configuration

Zero Velocity Speed Pick-up - Code Z, or N if None

Outputs 60 voltage pulses/rev., *not* ± 5 volts. Pulse amplitude is constant - approximately the supply voltage less $\frac{1}{2}$ volt. It requires a 5 to 15V dc supply. **Use below 100 rpm or in electrically noisy environments.**

Standard Speed Pick-up - Code A, or N if None

Outputs 60 voltage pulses/rev., *not* ± 5 volts. Its amplitude is proportional to speed. **Use Code Z pick-up below 100 rpm or in noisy environments.**

Code K - 1,100 Hz Wideband Output, N if 500 Hz

Add Suffix K for optional 1,100 Hz bandwidth on high frequency output.

1,100 Hz Output

± 10 Volt Outputs

Speed Pick-up

Foot Mount

S. HIMMELSTEIN AND COMPANY

2490 Pembroke Avenue, Hoffman Estates, IL 60169, USA • Tel: 847/843-3300 • Fax: 847/843-8488