

MCRT[®] 28000TB & MCRT[®] 29000TB **Low Capacity, Non-Contact mV/V TORQUEMETERS**

See Bulletin 7402 for DC Operated Torquemeter Version of These Products

- ✓ **2X and 4X Overload Ratings**
- ✓ **Hardened to EMI From Adjustable Speed Drives** (MCRT[®] 29000TB)
- ✓ **High Accuracy and High Stiffness to Inertia Ratio**
- ✓ **Bidirectional Operation Includes Stall**
- ✓ **Ferrite-free Rotary Transformer Coupling**
- ✓ **NIST Traceable Dead Weight Calibration**
* Calibration performed in our accredited metrology laboratory (NVLAP Lab Code 200487-0). For details see www.himmelstein.com or accreditation link at www.nist.gov
- ✓ **Unexcelled Immunity To Machinery Magnetic Fields**
- ✓ **Non-magnetic Titanium Shaft**



To excite and display Torque only, use a Model 701. To excite and display Torque, Speed and HP, use a Model 721. See Bulletins 370 & 371.



Torque Ranges: 10 to 400 ozf-in (0.07 to 2.83 N-m)

No Slip Rings, Brushes, LVDT's, Optical Paths or Radio Transmitters

S. HIMMELSTEIN AND COMPANY

2490 Pembroke Avenue, Hoffman Estates, IL 60169, USA • Tel: 847/843-3300 • Fax: 847/843-8488

Torquemeter Description

When installed between a driver and load, MCRT® 28000TB and 29000TB low capacity sensors *measure static (stall) and dynamic shaft torque and speed* (an option). A strain gaged titanium shaft senses torque and cancels bending and thrust. *Robust, ferrite-free rotary transformers* connect the gages to *noise immune* carrier amplifiers¹. They don't generate noise or wear, are immune to magnetic fields, noise, vibration, lubricants and other hostile environments.

The MCRT® 28000TB safely handles torques up to twice its rating; an MCRT® 29000TB safely handles torques up to four times its rating. High stiffness to inertia ratios makes these sensors ideal for dynamic applications. Additionally, the MCRT® 29000TB incorporates new technology that *hardens it to EMI generated by IGBT-based adjustable speed drives*. Both operate from stall to $\pm 15,000$ rpm or, to $\pm 25,000$ rpm with Option H. A dual track 512 PPR encoder is optional as is a line driver for its output(s).

General Specifications

Accuracy ² (combined nonlinearity and hysteresis - % of F.S.):	= < ± 0.10
Nonrepeatability (% of F.S.):	= < ± 0.05
Stability, 6 Months (% of F.S.):	= < ± 0.15
Rotational Effect on Zero (% of F.S.):	= < ± 0.05
Calibration Accuracy ³ (% of F.S. @ 75 deg. F., traceable to NIST):	= < ± 0.05
Temperature Effects:	
Zero (% of Range/deg. F.) and Span (% of Reading/deg. F.):	= < ± 0.002
Compensated Range:	+75 to +175 deg. F.
Minimum Usable Range:	-25 to +185 deg. F.
Storage Range:	-65 to +225 deg. F.
Output (nominal):	1.5 mV/V
Zero Balance:	= < $\pm 1\%$ of F.S.
Excitation Voltage:	3 - 6 volts rms, 3 kHz $\pm 10\%$, sine wave capable of driving a 90 ohm bridge.
Readout:	A strain gage carrier amplifier with the stated excitation. Use Himmelstein Series 701, 711, 721 or 751 Instruments for optimum performance.

Code N, Standard Performance

Notes:

- When ordered with amplifier and cable, the system is dead weight calibrated traceable to NIST.
- Based on end point method.
- If ordered with cable and amplifier, see note 1. Torquemeters only are dead weight calibrated with factory cable and amplifier. Calibration transfer is guaranteed only when used with a Himmelstein amplifier and cable with like part numbers.

- "F.S." denotes "Full Scale".
- "deg. F." denotes "degree Fahrenheit".
- Speed ratings are for continuous, bi-directional operation.
- These torquemeters operate in a condensing atmosphere, and if wetted with non-corrosive fluids and mud. When used under contaminated conditions, clean regularly or cover to deflect contaminants. They are not submersible.
- Specifications are subject to change without notice.

Other Features and Options: Designations for standard features and available options are listed below.

Optical Speed Pickup - Code Z, B or N if None

Outputs 512 TTL pulses/rev with a maximum pulse rate of 100 kHz. Needs 5 V @ 85 mA dc power. Three outputs are provided; two square waves in phase quadrature and a single index pulse per revolution. Output amplitude is greater than 2.4V (high) and 0.4V (low). Assuming customer furnished 2.7k Ω pull-up resistors, rise and fall times are less than 200 nS if the capacitive load is less than 100 pF. Greater capacitive loads such as unbuffered cables will severely degrade rise and fall times.

If fast transitions with minimal transmission line reflections are needed, specify Option Code B. This option provides a line driver to power the speed pickup and buffer all three of its outputs. A fourth output produces 1024 pulses per revolution with a 150 kHz maximum rate. All four outputs are without cable reflections and have nominal rise and fall times of 1 μ S for a 50 foot cable load. Input power is 10 - 15 Volts unregulated at 110 mA.

Standard Foot Mount - Code F, or N if None

Foot mounts provide a rigid stator mounting. They are needed if an encoder line driver is used. See the outline drawing for dimensions.

Maximum Speed Rating - Code H for 25,000 RPM or Code N if 15,000 RPM.

Order Number:

MCRT® 29000TB (1-2) N F Z H

Model No.

Torque Range

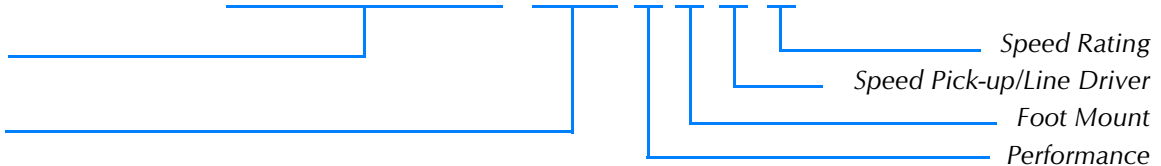

Standard Ratings, MCRT® 2800TB Series Low Capacity Non-Contact Torquemeters

MCRT® MODEL	TORQUE RANGE		TORQUE OVERLOAD		SPEED RATING		SHAFT STIFFNESS*	ROTATING INERTIA	MAX WT.
					Standard Code N	Optional Code H			
	[ozf-in]	[N-m]	[ozf-in]	[N-m]	[rpm]	[rpm]			
28000TB(1-1)	10	0.071	20	0.141	0 to ±15,000	0 to ±25,000	336	2.98X10 ⁻⁴	1.5
28000TB(2-1)	20	0.141	40	0.283	0 to ±15,000	0 to ±25,000	608	3.01X10 ⁻⁴	1.5
28000TB(5-1)	50	0.353	100	0.706	0 to ±15,000	0 to ±25,000	1,910	3.10X10 ⁻⁴	1.5
28000TB(1-2)	100	0.706	200	1.412	0 to ±15,000	0 to ±25,000	5,072	3.20X10 ⁻⁴	1.5
28000TB(2-2)	200	1.412	400	2.825	0 to ±15,000	0 to ±25,000	8,864	3.32X10 ⁻⁴	1.5
28000TB(4-2)	400	2.825	800	5.649	0 to ±15,000	0 to ±25,000	12,048	3.53X10 ⁻⁴	1.5

* Stiffness is conservatively rated and includes the torsion section and shaft ends.

Standard Ratings, MCRT® 2900TB Series Low Capacity Non-Contact Torquemeters

MCRT® MODEL	TORQUE RANGE		TORQUE OVERLOAD		SPEED RATING		SHAFT STIFFNESS*	ROTATING INERTIA	MAX WT.
					Standard Code N	Optional Code H			
	[ozf-in]	[N-m]	[ozf-in]	[N-m]	[rpm]	[rpm]			
29000TB(1-1)	10	0.071	40	0.283	0 to ±15,000	0 to ±25,000	608	3.01X10 ⁻⁴	1.5
29000TB(2-1)	20	0.141	80	0.565	0 to ±15,000	0 to ±25,000	1,616	3.07X10 ⁻⁴	1.5
29000TB(5-1)	50	0.353	200	1.412	0 to ±15,000	0 to ±25,000	5,072	3.20X10 ⁻⁴	1.5
29000TB(1-2)	100	0.706	400	2.825	0 to ±15,000	0 to ±25,000	8,864	3.32X10 ⁻⁴	1.5
29000TB(2-2)	200	1.412	800	5.649	0 to ±15,000	0 to ±25,000	12,048	3.53X10 ⁻⁴	1.5

* Stiffness is conservatively rated and includes the torsion section and shaft ends.

Dimensional Data

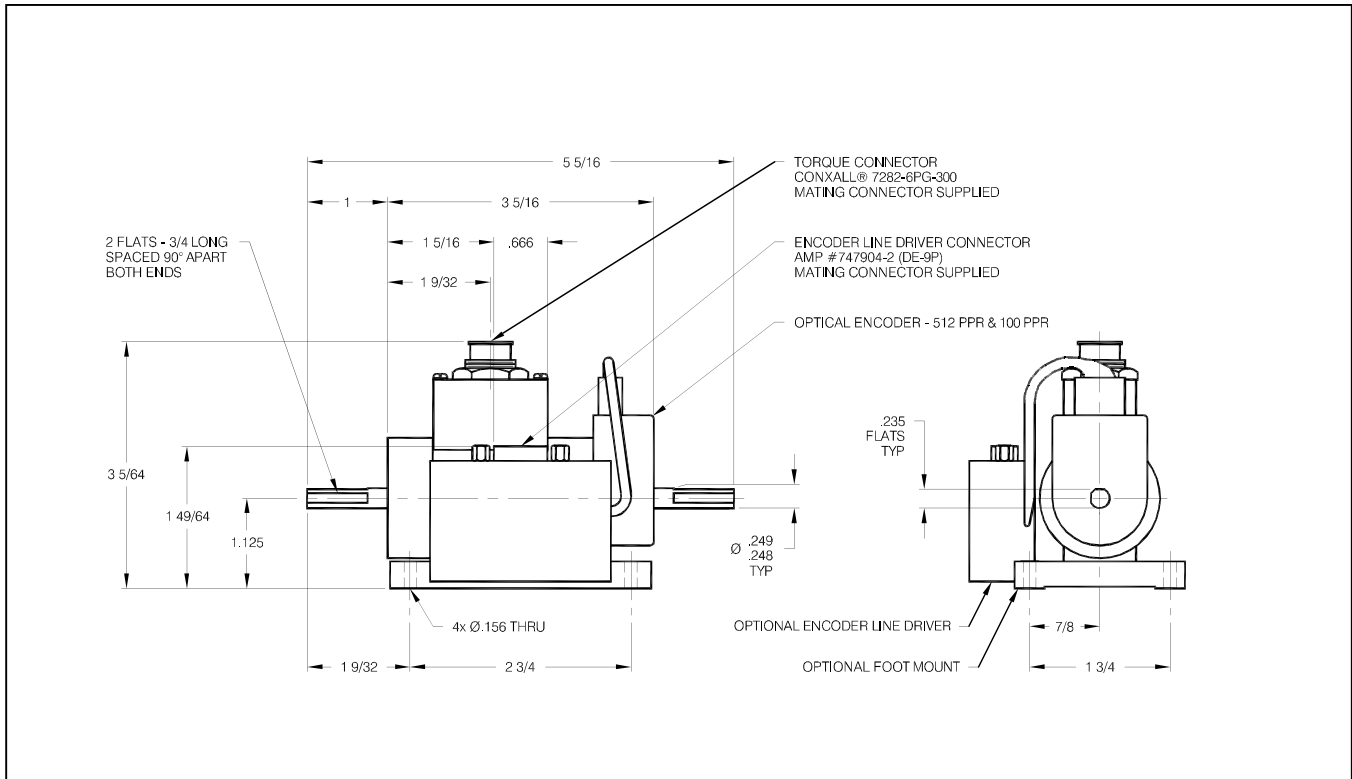

Patent Notice: Himmelstein torque measurement products are manufactured under one or more of the following U.S. Patents: RE26,501; 3,441,886; 3,531,748; 3,531,749; 3,717,029; 3,800,591; 3,961,526; 4,412,198; 4,555,956; 4,563,905; 4,616,512; 4,651,573; 4,790,175

MCRT[®] 28000T and MCRT[®] 29000T Electrical Interfaces

Torque Connections — Use twisted, individually shielded pairs; 2 pair for 4 wire cable, 3 pair for 6 wire cable. Shields are floated at sensor, grounded at amplifier.

Pin	Function	Comments
1	+ Excitation	3 - 6 Vrms 3 kHz \pm 10% sine wave capable of driving 90 ohms.
2	+ Excitation Sense	Feedback for excitation regulator to <i>keep the excitation constant at the torquemeter</i> ; used for 6 wire cables only. For 4 wire cables short Pin 1 to 2 and Pin 3 to 4; <i>excitation is constant at amplifier not at torquemeter</i> .
3	- Excitation Sense	
4	- Excitation	Return wire for 3 kHz excitation (1 above).
5	- Signal	Connect via shielded twisted wire pair to carrier amplifier input terminals.
6	+ Signal	

Code Z Speed Pickup Only

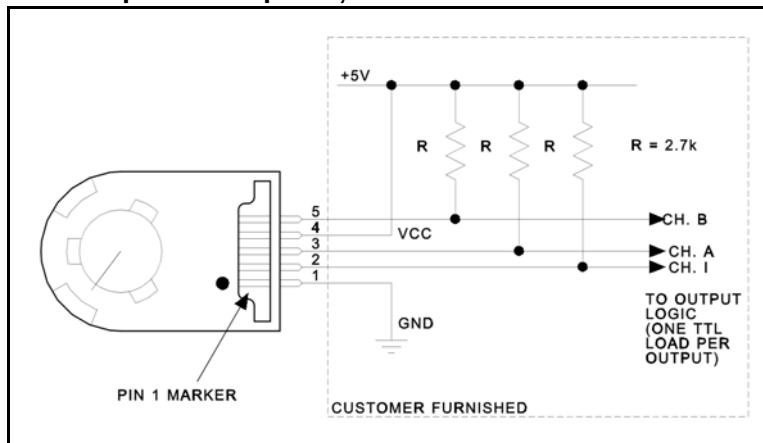

Notes Applicable to Code Z Pickup:

1. Mating connector is furnished.
2. 5 Volt dc power @ 85 mA, maximum is customer furnished.
3. Ch. A and Ch. B produce 512 pulses/rev (PPR) in phase quadrature. Ch. 1 produces 1 PPR. Maximum pulse rate is 100 kHz.
4. Pull-up resistors (shown) are customer furnished. They should be located as close as possible to the pickup; within 40 inches.
5. With 2.7 k Ω pull-up resistors and a maximum capacitive load of 100 pF, the rise and fall times for any combination of events will be no greater than 1 μ s and no less than 10 ns.
6. If a cable is used and fast transitions with minimal line reflections are needed, specify the Option B line driver described below.

Code Z Speed Pickup With Code B Line Driver

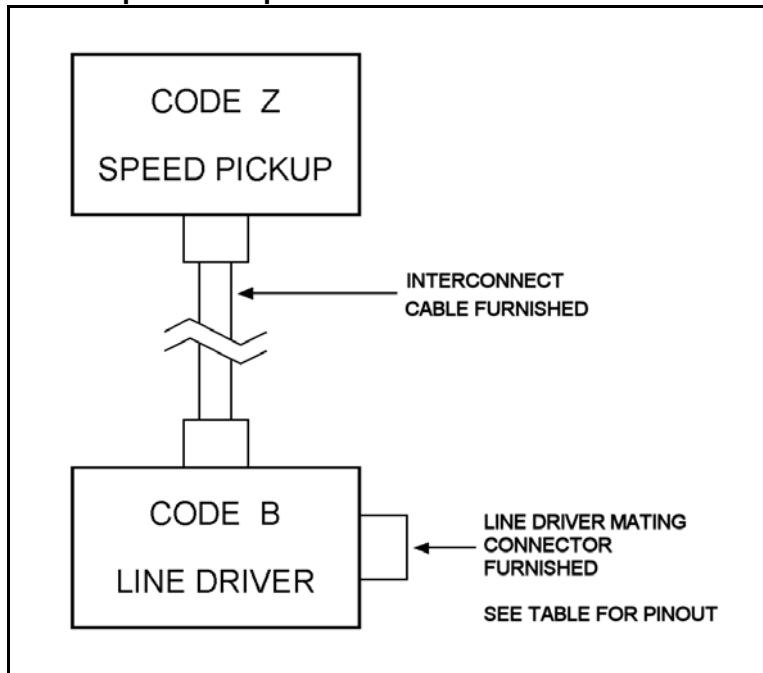

Notes Applicable to Code B Line Driver:

1. Line Driver mating connector and interconnect cable to speed pickup are furnished.
2. Connector pinout, as follows.

Pin	Function
1	Input Power: 10 to 15 V dc @ 110 mA
2	Output: Buffered Ch. A @ 512 PPR
3	Output: Buffered Ch. B @ 512 PPR
4	Output: Double Ch. A Rate @ 1024 PPR
5	Output: Buffered Ch. 1 @ 1 PPR
6	Ground

3. Maximum data rates are 100 kHz except double frequency output (Pin 4) is 150 kHz.
4. Outputs are without cable reflections and transition times are 1 μ s nominal, when connected to a 50 foot cable.
5. 10 - 15V dc power is customer furnished.